

AQUAELITE



Art. SF 018A



Art. SF 019A



Art. SF 020A

CONTENUTO DELLA CONFEZIONE

Package contents / Contenu de l'emballage

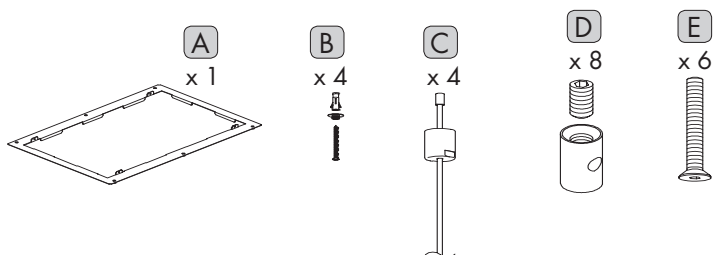

UTENSILI NECESSARI

Tools needed / Outils Nécessaires

Indossare guanti di protezione
Wear protective gloves
Utiliser des gants isolants de protection

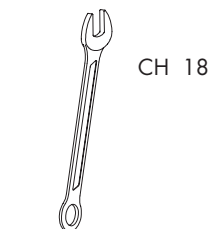
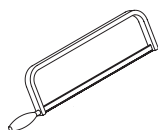
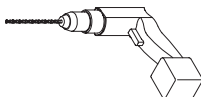

ATTENZIONE!!!!

Tutte le operazioni di installazione e manutenzione richiedono l'ausilio di NR. 2 OPERATORI SPECIALIZZATI
WARNING!!!!

All installation and maintenance operations require 2 QUALIFIED WORKER

ATTENTION : Toutes les opérations de pose et d'entretien nécessitent de Nr.2 opérateurs spécialisés

Art SF 018A

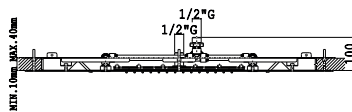
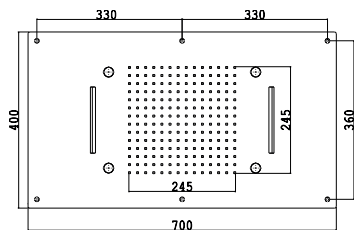

Art SF 019A

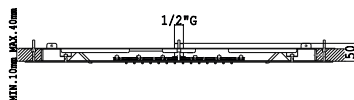
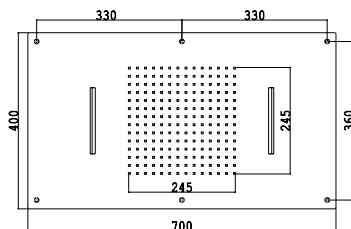

Art SF 020A

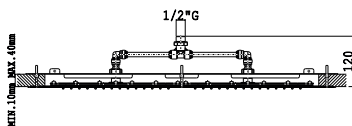
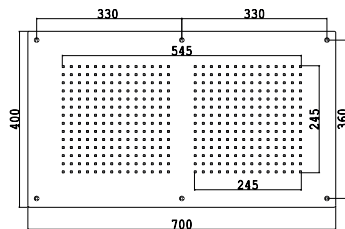

1 SCHEMA IMPIANTO IDRAULICO

Hydraulic system layout / Schéma d'installation hydraulique



SF 020A



x = 660 mm.
Y = 310 mm.
z = min 160 mm. / max 700 mm.

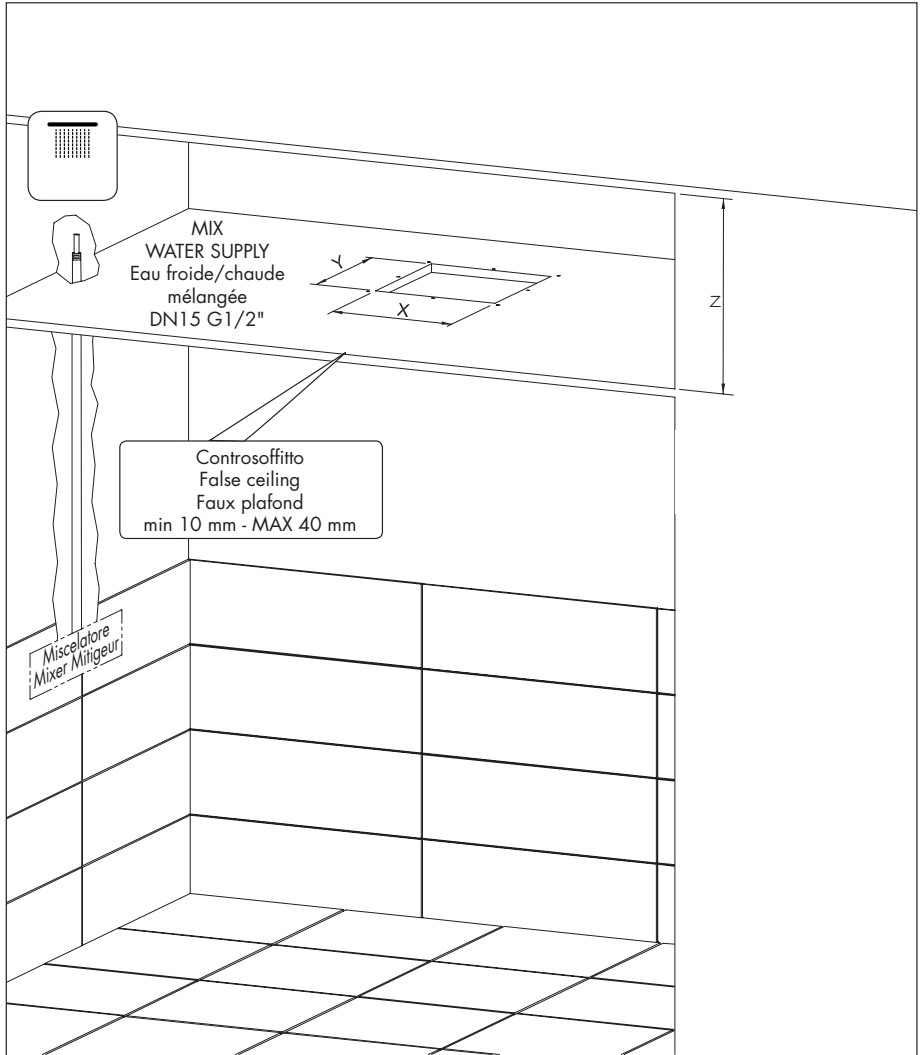

SCHEMA IMPIANTO IDRAULICO

Hydraulic system layout / Schéma d'installation hydraulique

2



SF 019A



x = 660 mm.
Y = 310 mm.
z = min 160 mm. / max 700 mm.

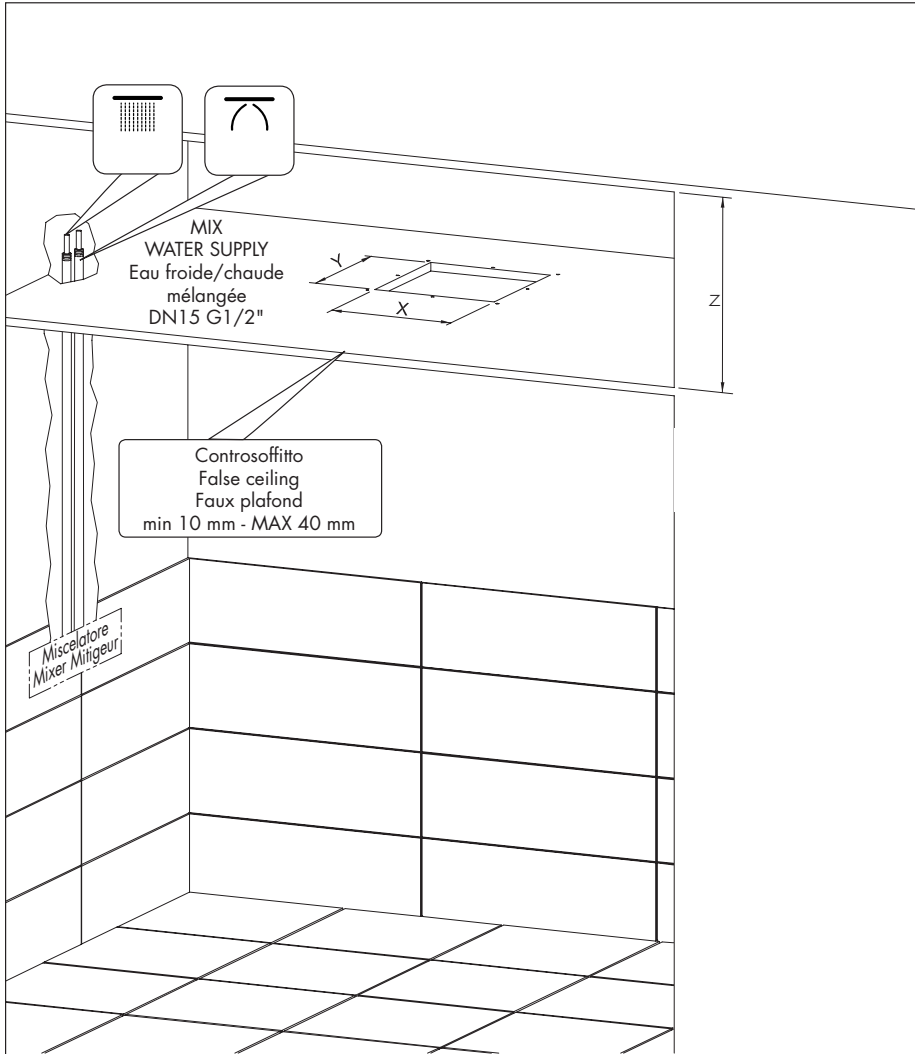



SF 018A



x = 660 mm.
Y = 310 mm.
z = min 160 mm. / max 700 mm.

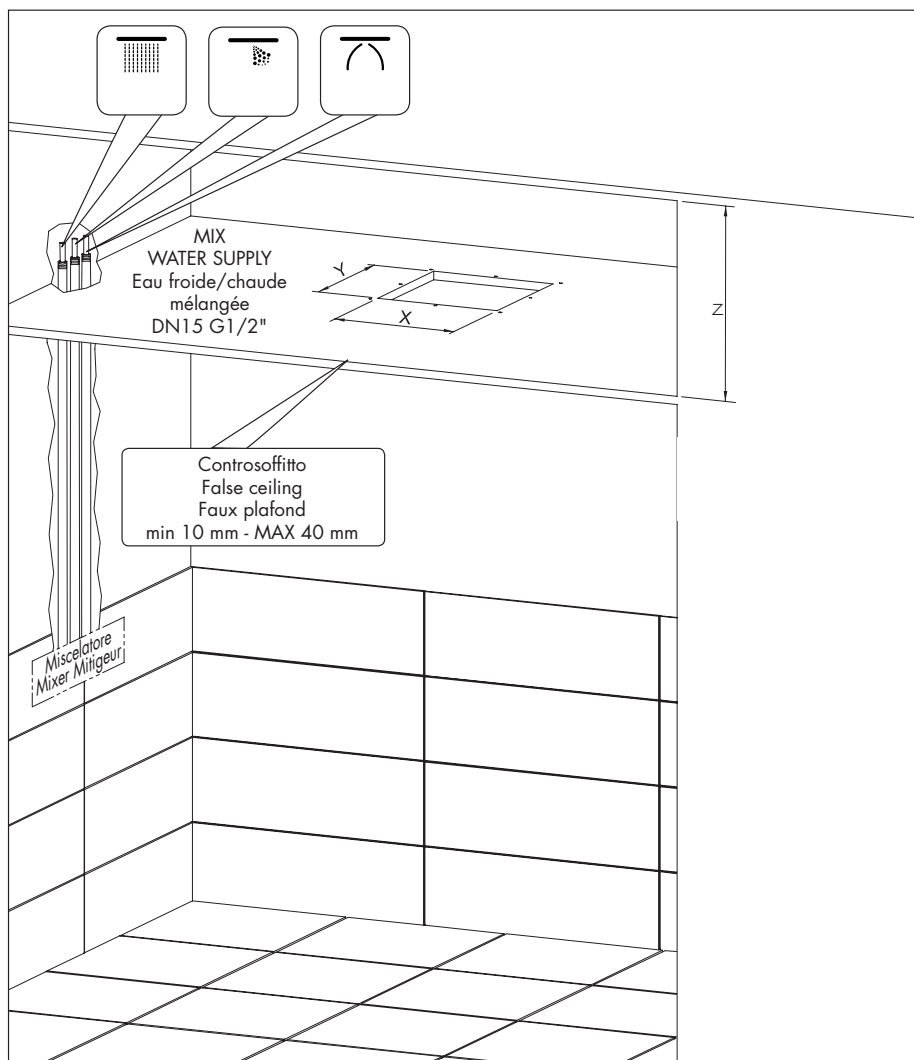

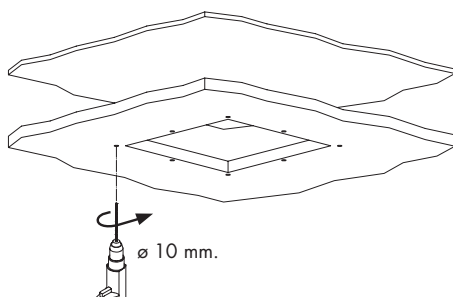
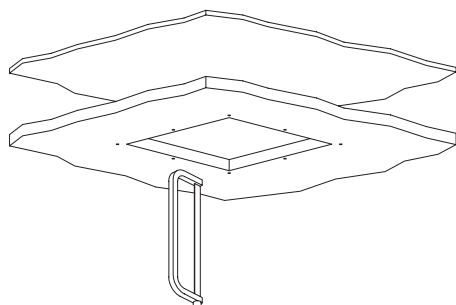
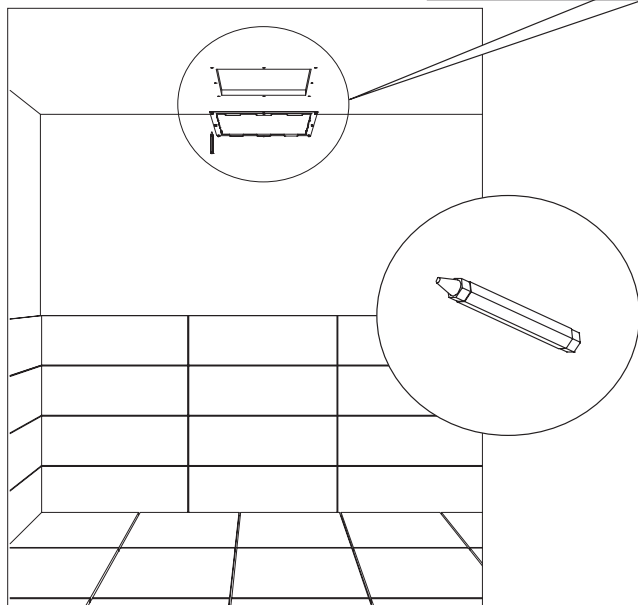
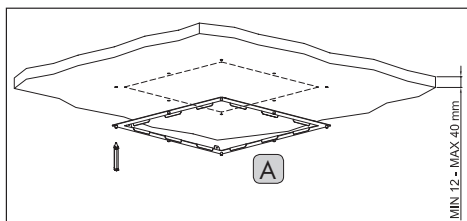

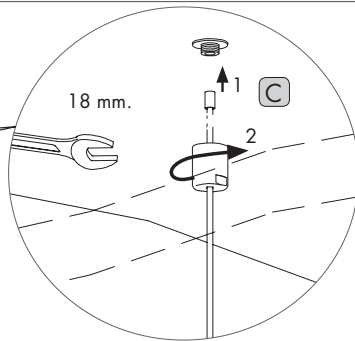
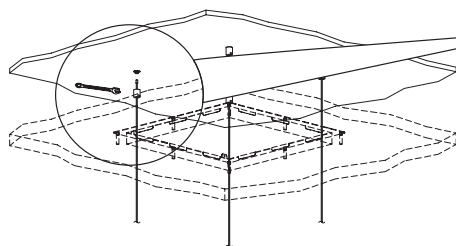
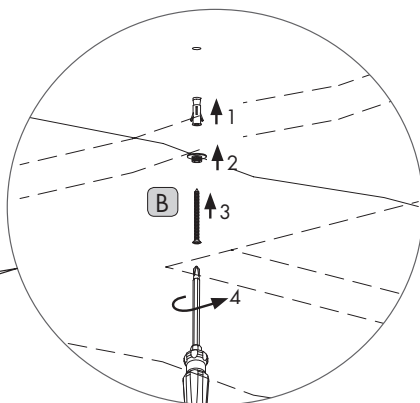
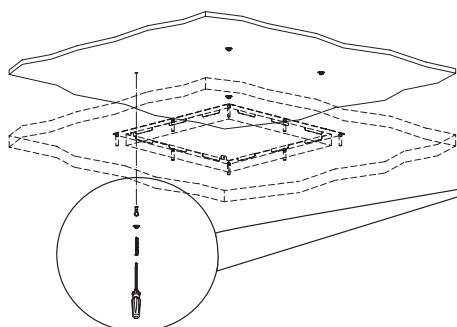
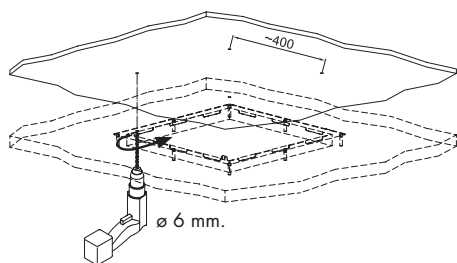
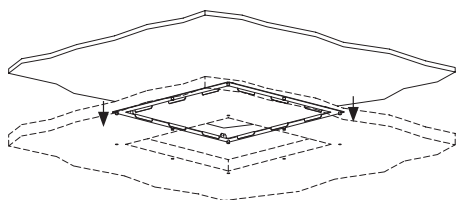

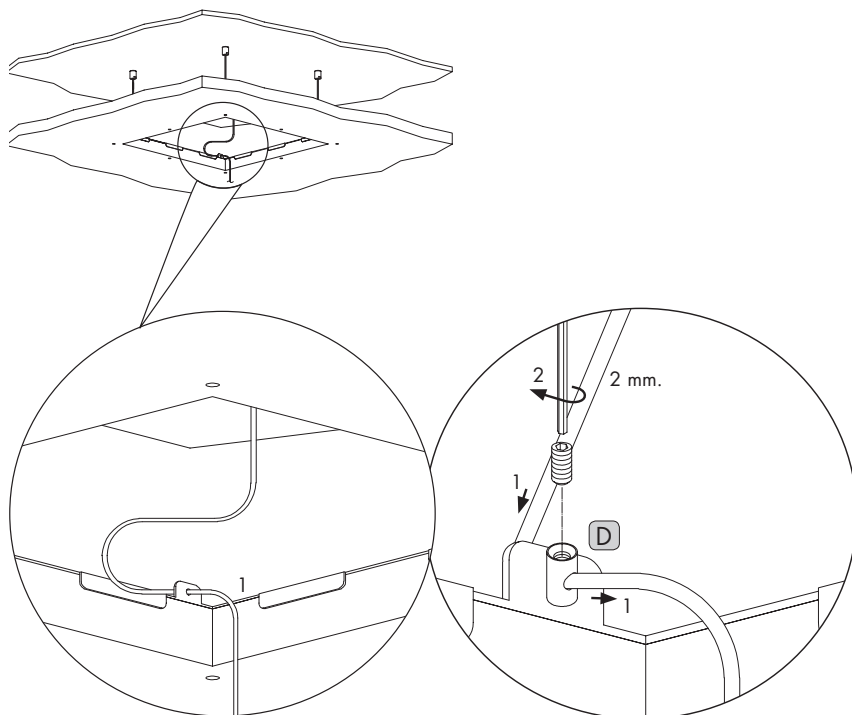

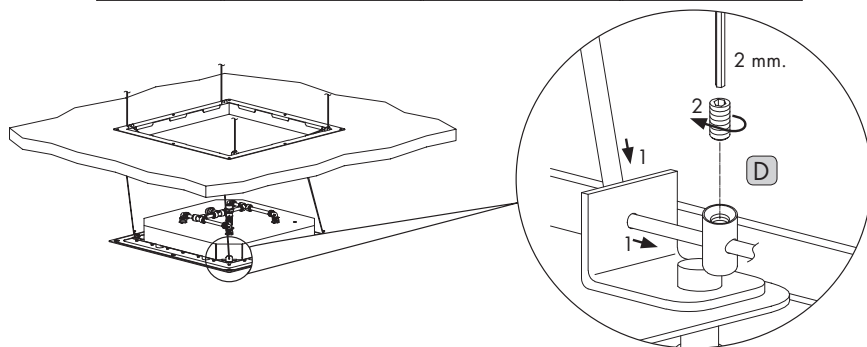
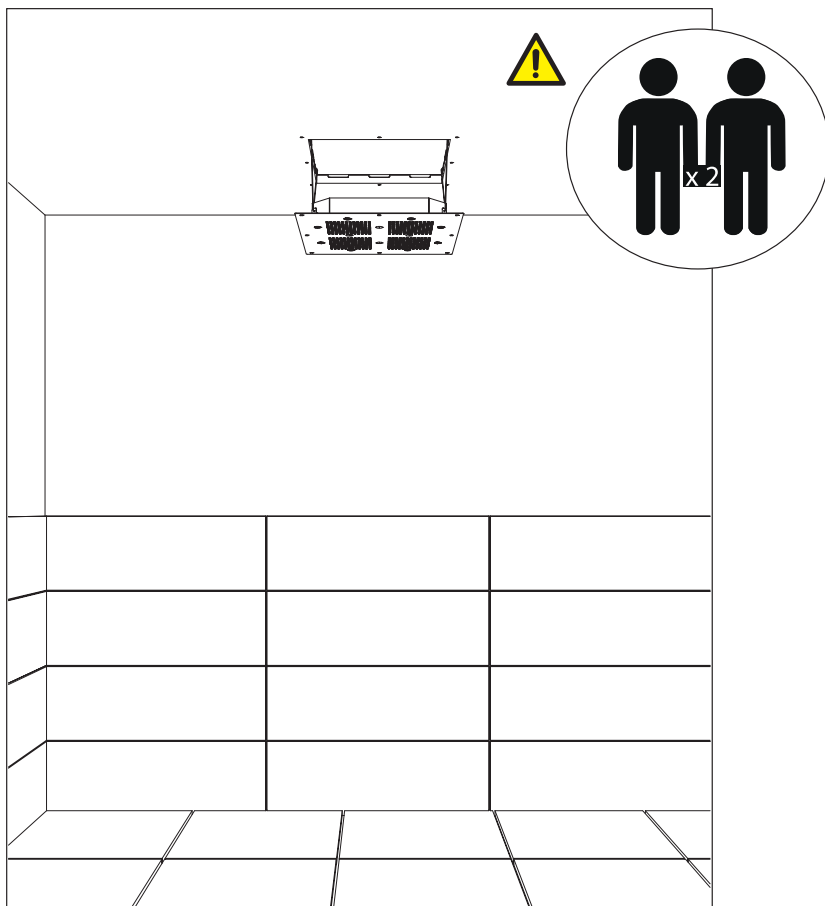



- Effettuare il collegamento idraulico/elettrico in base alla tipologia di soffione (Ved. pag. 4÷6)
- Make the connection to the hydraulic/electrical system according to the type showerhead. (see pag. 4÷6)
- Effectuer le branchement hydraulique/électrique en fonction du type de produit (voir pages 4÷6)

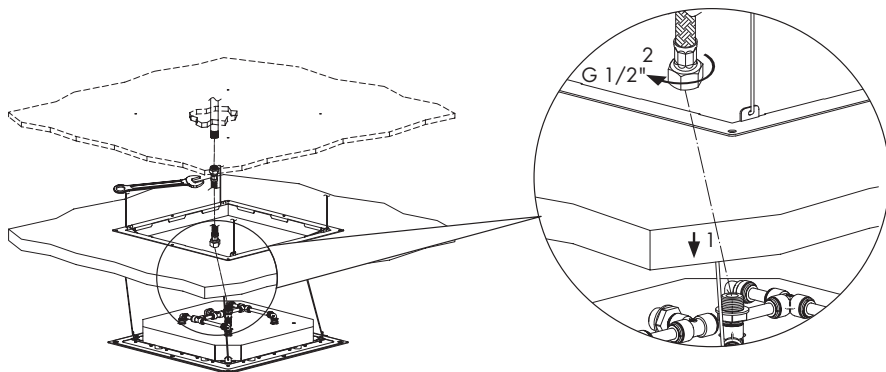

- Fissare il soffione al controsoffitto e serrare le viti come indicato nella figura M, prestando particolare attenzione a non rovinare la finitura.
- Install the showerhead to the false ceiling and tighten the screw as shown in the figure M, be carrefully, not schrath the surface.
- Fixer le produit à faux-plafond et serrer les vis comme indiqué dans la figure "M", en accordant une attention particulière à ne pas abimer la finition.

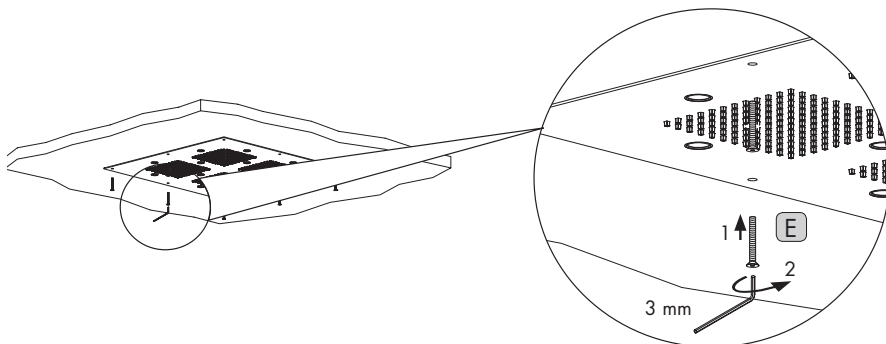

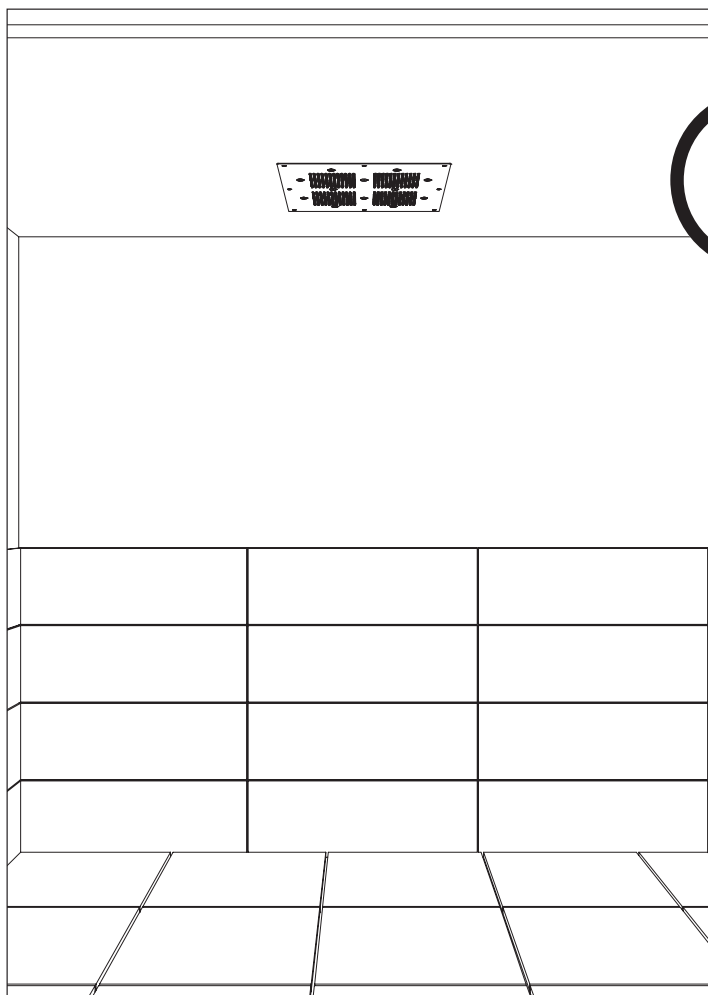

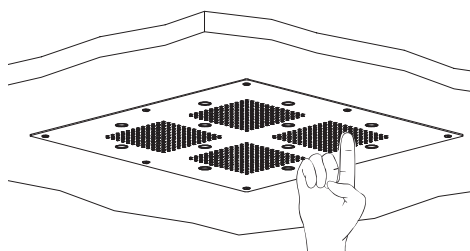

- Periodicamente pulire gli ugelli anticalcare come mostrato in figura "a"
- Periodically clean the nozzles to remove any lime scale as shown in Illustration "a"
- Nettoyer périodiquement les picots anticalcaire comme visualisé dans la figure "a".

Per preservare la qualità del prodotto AQUAelite si raccomanda di pulire le superfici in finitura esclusivamente con acqua e sapone neutro asciugandole con un panno morbido.

Non utilizzare detergenti o detersivi abrasivi o contenenti alcool, acidi, candeggina, cloro, solventi chimici, spugne abrasive, paglie metalliche, etc.

L'acqua contiene calcare in quantità variabili, il quale può depositarsi sulla superficie del prodotto formando macchie e depositi. E' possibile evitare la formazione di macchie di calcare pulendo ed asciugando il prodotto dopo ogni utilizzo.

Per evitare la formazione di calcare sugli ugelli strofinarli periodicamente con un panno umido.

In order to maintain the quality of AQUAelite products, surfaces must be cleaned exclusively using soapy water and dried with a soft cloth. Never use detergents, powders or creams containing alcohol, acid, bleach, solvents, chemical agents, metal or abrasive sponges, etc.

Water contains limestone in variable quantity, which can remain on the surfaces leaving spots and forming deposits.

In order to avoid limestone deposits clean and dry the product immediately after use. It is possible to prevent limestone deposits on nozzles by regularly rubbing with a damp cloth.

Pour préserver la qualité du produit AQUAelite est fortement recommandé de nettoyer les surfaces uniquement avec de l'eau et du savon neutre, ensuite sécher avec un chiffon délicat.

N'utiliser PAS des détergents ou produits abrasifs ou avec un contenu d'alcool, acides, candéggine, chlôre, solvants chimiques, éponges abrasives, paglie métalliques, etc.

L'eau contient du calcaire en quantité variable, il peut se déposer sur la surface du produit et former des taches ou sédiments.

Il est possible d'éviter la formation de taches de calcaire en nettoyant et séchant le produit après chaque utilisation.

Pour éviter la formation de calcaire dans/sur les picots, il est fortement conseillé de les nettoyer périodiquement avec un chiffon délicat et humide.

DATI TECNICI

Technical Information / Données Techniques

Dati tecnici generali per l'impianto idraulico

Pressione minima di esercizio: 1.5 bar
Pressione di esercizio: campo di impiego ottimale consigliato 2.5 - 4 bar
Pressione massima di esercizio: 5 bar
(Per pressioni idrauliche superiori si consiglia l'utilizzo di un riduttore di pressione)
Temperatura massima di esercizio: 65 °C
I soffioni a parete sono dotati di limitatore di portata 12 lt/min. (ove possibile).

Funzionamento minimo dei soffioni ad incasso:

Getto a pioggia: 16 lt/min. - 1.5 bar
Cascata singola: 10 lt/min. - 2 bar
Doppia cascata: 14 lt/min. - 2 bar

Funzionamento ottimale dei soffioni ad incasso:

Getto a pioggia: 18 lt/min. - 2.5 bar
Cascata singola: 14 lt/min. - 2.5 bar
Doppia cascata: 17 lt/min. - 2.5 bar



PROTEZIONE AMBIENTALE

I dispositivi elettrici ed elettronici non devono essere considerati rifiuti domestici. I consumatori sono obbligati dalla legge a restituire i dispositivi elettrici ed elettronici alla fine della loro vita utile ai punti di raccolta collettivi preposti per questo scopo o nei punti vendita.

Technical information for the hydraulic system

Minimum operating pressure: 1.5 bar
Operating Pressure: Optimal recommended use 2.5- 4 bar
Maximum operating pressure: 5 bar
(for higher hydraulic pressure it is recommended a pressure reducer)
Maximum operating temperature: 65 °C
Wall mount shower heads are equipped with a 12 l/m flow rate reducer (where possible).

Minimum supply required for false ceiling shower heads:

Rain function: 16 l/m - 1.5 bar
Cascade function: 10 l/m - 2 bar
Double cascade function: 14 l/m - 2 bar

Optimal supply for false ceiling shower heads:

Rain function: 18 l/m - 2.5 bar
Cascade function: 14 l/m - 2.5 bar
Double cascade function: 17 l/m - 2.5 bar



ENVIRONMENTAL PROTECTION

Electrical and electronic equipment is not to be treated as domestic refuse.
Consumers are obliged by law to dispose of no-longer useful electrical and electronic equipment at the appropriate collection or sales points.

Données techniques générales pour installation hydraulique

Pression minimale d'exercice: 1.5 bar
Pression d'exercice optimale: 2.5 - 4 bar
Pression maximale d'exercice: 5 bar
(pour pressions hydrauliques supérieures, l'utilisation d'un réducteur de pression est fortement recommandée)
Température maximale d'exercice : 65 °C
Les pommes de douche à mur sont équipées d'un limiteur de débit d'eau à 12 lt/min. (ou possible).

Fonctionnement minimal des plafonds de douche à encastrer à faux-plafond:

Jet pluie: 16 lt/min. - 1.5 bar
Jet cascade single: 10 lt/min. - 2 bar
Jet cascade double: 14 lt/min. - 2 bar

Fonctionnement optimale des plafonds de douche à encastrer à faux-plafond:

Jet pluie: 18 lt/min. - 2.5 bar
Jet cascade single: 14 lt/min. - 2.5 bar
Jet cascade double: 17 lt/min. - 2.5 bar



ENVIRONNEMENT

Les dispositifs électriques et électroniques NE doivent PAS être considérés comme des déchets domestiques.
Les consommateurs sont obligés par la loi à retourner les dispositifs électriques et électroniques, à la fin de leur vie utile, aux points de collecte collectifs faits pour ça ou aux points de vente.

NOTE

Notes / Note

AQUAELITE

AQUAELITE / ANPA S.R.L.
Via Dello Sport, 16/18
2106 Gavirate (VA) - Italy

+39 0322 732 906
www.aquaelite.it
info@aquaelite.it